

\$ Saver Product

- ◆ 698 - 2,700 MHz Multi-Band Frequency Range
- ◆ 5 & 10 W Power Rating
- ◆ Low RF Insertion Loss
- ◆ 20 dB Isolation
- ◆ RoHS compliant
- ◆ Low Cost N Design

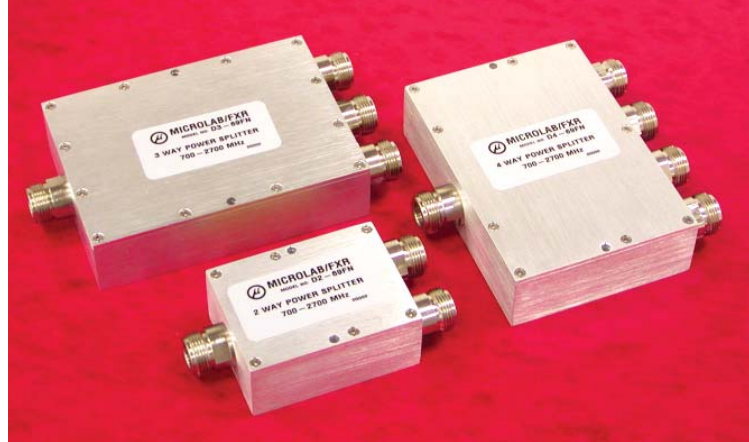

Microlab Model Dx-69FN series of Wilkinson style Power Dividers has been designed for low power applications where output isolation is preferable over lowest possible loss. The wide frequency range of this design allows use with multiband antennas and leaky cable systems.

Lower loss dividers which enhance receive sensitivity and preserve transmitted power are available in the reactive splitters such as Dx-55FN and Dx-85FD series. (01/13)

Bandwidth:	698 - 2,700 MHz
Impedance:	50Ω nominal
Environment:	-30 to +60°C, Indoor
Housing:	Passivated Aluminum
Connectors:	N (f) triplate

Model Number	No. of Ways	Split Loss	Output Isolation	Insertion Loss, max.	Amplitude Balance	VSWR All Ports	Power Rating*
D2-69FN	2	3 dB	>20 dB	0.4 dB	<0.3 dB	<1.25:1	10W avg.
D3-69FN	3	4.8 dB	>20 dB	0.5 dB	<0.6 dB	<1.30:1	5W avg.
D4-69FN	4	6 dB	>20 dB†	0.6 dB	<0.3 dB	<1.25:1	10W avg.
D6-69FN	6	7.8 dB	>20 dB	1.0 dB	<0.8 dB	<1.40:1	5W avg.
D8-69FN	8	9 dB	>20 dB	1.0 dB	<0.8 dB	<1.40:1	5W avg.

†>20 dB 800 - 2500 MHz; >19 dB 698 - 2700 MHz *Used as divider into load(s) with VSWR <1.2:1

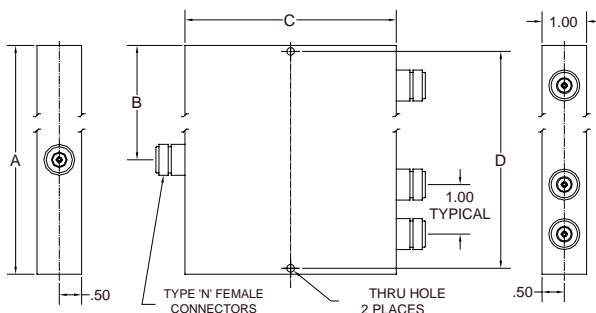

Dimensions and Weight: Inches (mm); Wt: oz (g) nom.

	D2-69FN	D3-69FN	D4-69FN	D6-69FN	D8-69FN
A	1.81 (46)	2.91 (74)	4.00 (101)	6.50 (165)	8.36 (212)
B	0.91 (23)	1.46 (37)	2.00 (51)	3.25 (83)	4.18 (106)
C	2.40 (61)	4.06 (103)	2.80 (71)	5.95 (151)	4.80 (122)
D	1.61 (41)	2.71 (69)	3.82 (97)	6.15 (156)	8.05 (204)
Ø	0.12 (3.0)	0.12 (3.0)	0.12 (3.0)	0.12 (3.0)	0.12 (3.0)
Wt.	6.6 (185)	14.8 (415)	15.2 (395)	38.4 (1.10k)	41.1 (1.15k)